



Distributed Generation Procedures & Guidelines Manual for Members



October 2016

GENERAL

In order to receive service from the Cooperative, a customer must join or become a "Member" of the Cooperative. Throughout this manual, customers will be referred to as "Members." For more information about the cooperative membership application process, including any applicable membership fees or deposits, see the Cooperative to request new member information.

It is the intent of the Cooperative to allow Members to install Distributed Generation (DG), provided the Member's DG facility does not adversely affect the Cooperative. The Member must conduct his/her own analysis to determine the economic benefit of DG operation.

A DG facility that is not connected to the Cooperative's system in any way is known as "stand-alone" or "isolated" DG. The Member may operate a DG facility in stand-alone or isolated fashion as long as such DG facility does not adversely affect the Cooperative's system. A DG facility connected in any way to the Cooperative's system shall be considered as in "parallel." For purposes of this Manual, a DG facility is considered operating in "parallel" anytime it is connected to the Cooperative's system in any way, even if the Member does not intend to export power. All provisions of this Manual shall apply to parallel operation of DG facilities as so defined.

This Manual is not a complete description or listing of all laws, ordinances, rules and regulations, nor is this Manual intended to be an installation or safety manual. The Member requesting to interconnect a DG facility to the Cooperative's system is responsible for and must follow, in addition to all provisions of this Manual, the Cooperative's *Tariffs for Electric Service*, the Cooperative's *Line Extension Policy*, the *Policies and Procedures* of the Cooperative's power supplier where applicable, the *Policies and Procedures* of the Cooperative's transmission service provider where applicable, the current *IEEE 1547 Standard Guide for Distributed Generation Interconnection* (a copy is on file at the Cooperative for inspection along with information so the Member may obtain his/her own copy), other applicable IEEE standards, applicable ANSI standards, including ANSI C84.1 Range A and any other applicable governmental and regulatory laws, rules, ordinances or requirements. All legal, technical, financial, etc. requirements in the following sections of this Manual must be met prior to interconnection of the DG facility to the Cooperative's system.

A Member may serve all load behind the meter at the location serving the DG facility but will not be allowed to serve multiple meters, multiple consuming facilities or multiple Members with a single DG facility or under a single DG application.

DG facilities larger than 700 kW and facilities rated to produce an amount of electricity greater than the amount of electricity the Member for whom the DG is installed is reasonably expected to consume are not covered by this Manual and will be considered by the Cooperative on a non-discriminatory case-by-case basis.

I. DETERMINE THE CATEGORY OF DISTRIBUTED GENERATION FACILITY

1) Connection Level Category

- a) Connected to the Cooperative's system
The Member requests and/or the Member's DG facility requires connection to the Cooperative's system. All provisions of this manual cover this category.
- b) Connected to the Cooperative's Power Supplier's system
The Member requests and/or the Member's DG facility requires connection to the Cooperative's Power Supplier's system. This manual does NOT cover this category. The Member should contact the Cooperative's Power Supplier directly.

2) Ownership of Facilities

The Member shall own and be solely responsible for all expenses, installation, maintenance and operation of all facilities, including all power generating facilities at and beyond the point of delivery as defined in the Cooperative's tariffs.

3) Power Export Category

- a) Parallel – no power export
The Member operates a DG facility connected in any way to the Cooperative system but with no intention to export power.
- b) Parallel – power generated to be both consumed and exported
The Member operates a DG facility connected in any way to the Cooperative's system designed primarily to serve the Member's own load but with the intention to export excess power.
- c) Parallel – Other
The Member operates a DG facility where either the power generated is intended for export only or where the DG facility is rated to produce an amount of electricity greater than the amount of electricity the Member for whom the DG is installed is reasonably expected to consume: This manual does not cover this category. The Cooperative will consider applications for service under this category on a case-by-case basis.

4) Qualifying or Non-Qualifying Category

- a) Qualifying Facilities (QF) are defined by the Public Utility Regulatory Policies Act of 1978 (PURPA). Refer to CFR Title 26, Volume 4, Sec. 292.204.
- b) The distinction between QF and Non-Qualifying Facilities (NQF) mainly deals with fuel use.

(1) A QF is defined as electric generation with a capacity of not more than 2 MW provided by renewable energy technology, as defined by PURPA, installed on a retail electric customer's (Member's) side of the meter. In general, this means that the DG must have as its primary energy source biomass, waste, renewable resources, geothermal resources or any combination. See PURPA for a full description.

- (2) DG facilities not designated as QF under the provisions of PURPA will be considered NQF by the Cooperative.
 - c) The Cooperative will provide interconnection for a DG facility to Members, subject to the provisions of this Manual and all other applicable rules and regulations.
 - d) The Cooperative will purchase power from a Member with a DG facility that is a QF, subject to the provisions of this policy and other applicable rules and regulations.
 - e) The Cooperative may choose to provide interconnection and may choose to purchase power from a Member with a DG facility that is an NQF at the sole discretion of the Cooperative as determined on a case-by-case basis.
- 5) Size Category
- a) Facilities 50 kW and smaller
Facilities \leq 50 kW of connected generation will be placed in this size category unless the Member requests connection under the $>$ 50 kW size category.
 - b) Facilities above 50 kW and below 700 kW
Facilities $>$ 50 kW and below 700 kW of connected generation will be placed in this size category. Facilities \leq 50 kW may be placed in this size category if so requested by the Member.
 - c) Facilities above 700 kW of connected generation
Not considered under this manual.

II. MEMBER'S INITIAL REQUIREMENTS

- 1) Notification
 - a) The Member must meet all the Cooperative's membership and service requirements in addition to the requirements in the Manual.
 - b) The rated capacity of the Member's DG must not exceed the Cooperative's service capacity.
 - c) Anyone owning or operating a DG facility in parallel with the Cooperative's system must notify the Cooperative of the existence, location and category of the DG facility, whether the Member intends to export power to the Cooperative or not.
- 2) Service Request
 - a) In order to interconnect a DG facility to the Cooperative system, the Member must first submit to the Cooperative "Cooperative Application for Interconnection and Parallel Operation of Distributed Generation," using the form included in this manual.
 - b) A separate form must be submitted for each facility.

3) Submit a DG Plan

- a) As a part of the application, the Member shall submit a plan detailing the electrical design, interconnection requirements, size, and operational plans for the DG facility (the “DG plan”). Either at the time of submission or at any time during the review process, the Cooperative may require additional information or may require the DG plan to be prepared by a Professional Engineer registered in the state of Texas.
- b) In the case of DG facilities (i) to be operated in parallel with the Cooperative’s system, (ii) with no intention to export power to the Cooperative and (iii) that are of standard design and intended entirely as emergency or back-up power supply for the facility, the Cooperative may, at its sole discretion, waive the application fee.
- c) Prior to review of the application and DG plan by the Cooperative, the Member shall pay an application fee as indicated below. A separate fee must be submitted for each DG facility.

DG Size (Connected Load)	Application Fee	Additional Engineering Fee
< 50 kW	None	None
50 kW to 700 kW	\$ 250	As Required
> 700 kW	Not covered by this manual	

III. COOPERATIVE AND POWER SUPPLIER REVIEW PROCESS

1) Plan Review Process

- a) The Cooperative and its Power Supplier, if requested by the Cooperative, will review the application and accompanying documents, plans, specifications, and other information provided and will return an interconnection analysis to the Member within 60 days of receipt of final plans and specifications.
- b) Technical review will be consistent with guidelines established by the most recent *IEEE Standard 1547 Guide for Distributed Generation Interconnection*. The Member may be required by the Cooperative to provide proof that their DG Facilities have been tested and certified by applicable IEEE guidelines.
- c) If corrections or changes to the plans, specifications and other information are to be made by the Member, the 60 day period may be reinitialized when such changes or corrections are provided to the Cooperative. In addition, any changes to the site or project requiring new analysis by the Cooperative may require additional cost and a new DG plan. The cost will be determined by the Cooperative and shall be paid by the Member.
- d) The Member acknowledges and agrees that any review or acceptance of such plans, specifications and other information by the Cooperative and/or its Power

Supplier shall not impose any liability on the Cooperative and/or its Power Supplier and does not guarantee the adequacy of the Member's equipment or DG facility to perform its intended function. The Cooperative and its Power Supplier disclaim any expertise or special knowledge relating to the design or performance of generating installations and does not warrant the efficiency, cost-effectiveness, safety, durability, or reliability of such DG installations.

- e) In the event it is necessary at the time of initial interconnection or at some future time for the Cooperative and/or its Power Supplier to modify electric delivery systems in order to serve the Member's DG facilities and/or purchase or continue to purchase the output of the Member's DG facilities, or because the quality of the power provided by the Member's DG adversely affects the Cooperative's and/or its Power Supplier's delivery system, the Member will be responsible to pay the Cooperative and/or its Power Supplier in advance for all costs of modifications required for the interconnection of the Member's DG facilities.

IV. SALES TO AND PURCHASES FROM A DG FACILITY

1) For all DG where the Member desires to export power

- a) All DG facilities shall be billed under one of the Cooperative's existing rate tariffs.
- b) All sales of electric power and energy by the Cooperative to a Member shall be consistent with the applicable retail rate schedule established by the Cooperative as if there were no DG installation at the Member's premises, including any charges in the Cooperative's DG tariff.
- c) The Member shall pay all rates and charges so listed.
- d) Neither the Cooperative nor its Power Supplier is under any obligation to purchase power from a NQF.
- e) All self-generated energy must be consumed on-site. No wheeling of self-generated energy from one site to another site will be permitted.
- f) The Customer shall be subject to any market charges related to the Customer's DG facility, including but not limited to Scheduling, Dispatching and Energy imbalance.

2) For QF \leq 50 kW where the Member desires to export power:

- a) When energy supplied by the Cooperative exceeds the energy supplied by the Member during a billing period, the net energy (kWh) supplied by the Cooperative to the Member, shall be billed by the Cooperative in accordance with the rates and charges under the cooperative's applicable rate schedule.
- b) When the energy supplied by the Member exceeds the energy supplied by the Cooperative during a billing period, the monthly charge and/or minimum of the retail rate schedule shall be billed, and the excess energy (kWh) generated by the Member and delivered back to the Cooperative, within the billing period, shall be credited to the Member at the Cooperative's Monthly Avoided Cost Rate provided by the Cooperative's wholesale power supplier. If credits for excess energy are greater than the member's monthly bill, the credit will be carried forward to the following billing period. If a credit balance remains at the end of

- the calendar year, a refund of the entire credit balance will be provided to the member.
- c) Monthly banking of energy (kWh) supplied by the Member, exceeding the energy supplied by the Cooperative during a billing period, will not be allowed.
 - d) Determination of billing shall be accomplished by interconnection through one meter with two registers capable of measuring in-flow and out-flow at the point of delivery of electric service.
 - e) The Member shall sign an approved interconnection agreement with the Cooperative.
 - f) Any renewable energy credits (REC's) resulting from the operation of the DG are the property of the DG Member unless sold or otherwise transferred by the Member.
- 3) For QF > 50 kW and < 700 kW where the Member desires to export power:
- a) All energy (kWh) supplied by the Cooperative to the Member, during the billing period, shall be billed by the Cooperative in accordance with the rates and charges under the cooperative's applicable rate schedule for the Member.
 - b) There will be no netting of energy (kWh). All excess energy (kWh) generated by the Member's qualifying facility during the billing period, not consumed instantaneously by the Member, and delivered back to the Cooperative within the billing period, shall be credited to the Member at the Cooperative's Monthly Avoided Cost Rate provided by the Cooperative's wholesale power supplier. If credits for excess energy are greater than the member's monthly bill, the credit will be carried forward to the following billing period. If a credit balance remains at the end of the calendar year, a refund of the entire credit balance will be provided to the member.
 - c) Determination of billing shall be accomplished by interconnection through one meter with two registers capable of measuring in-flow and out-flow at the point of delivery of electric service.
 - d) The Member shall sign an approved Agreement for Interconnection of Distributed Generation with the Cooperative.
 - e) In addition to all other charges, the Cooperative may bill the Member for any additional facilities charges as determined by the Cooperative and appended to the Interconnection Agreement.
 - f) Any renewable energy credits (REC's) resulting from the operation of the DG are the property of the DG Member unless sold or otherwise transferred by the Member.
- 4) The Cooperative shall not be required to make any purchases that will cause the Cooperative to no longer be in compliance with any applicable contracts or all-power contract requirements with its power supplier.

V. MEMBER'S RESPONSIBILITY PRIOR TO OPERATION

1) Line Extension and Modifications to Cooperative Facilities

- a) As a part of the interconnection analysis performed by the Cooperative, the Member will be provided with an estimate of any line extension or other cost to be incurred in providing electric delivery service to the Member's DG facility.
- b) Notwithstanding the Cooperative's line extension policy, the Member shall pay in advance the full cost of the construction of any transmission, substation, distribution, transformation, protective, or other facilities or equipment which, at the sole discretion of the Cooperative and/or its Power supplier, is required to serve the Member's DG facility.
- c) In the event it is necessary at the time of initial interconnection or at some future time for the Cooperative and/or its Power Supplier to modify electric delivery systems in order to serve the Member's DG facilities and/or purchase or continue to purchase the Member's output, or because the quality of the power provided by the Member's DG adversely affects the Cooperative and/or its Power Supplier's delivery system, the Member will reimburse the Cooperative and/or its Power Supplier for all costs of modifications required for the interconnection of the Member's DG facilities.
- d) In the event the Cooperative at any time in the future changes primary voltage of facilities serving the DG facility such that metering equipment, transformers and/or any other Member-owned equipment must be changed to continue receiving service at the new primary voltage level, the full cost of the change will be borne by the Member.
- e) In all cases, the Member shall pay the full cost of the installation of a visible load break disconnect switch by and to the sole specification of the Cooperative. The switch will be readily accessible to Cooperative personnel and of a type that can be secured in an open position by a Cooperative lock.

2) Applicable Regulations

The DG facility shall be installed and operated subject to and in accordance with the terms and conditions set forth in the Cooperative's rules, regulations, bylaws, rates and tariffs, as amended from time to time, and, if applicable, approved by the Cooperative's board of directors, which are incorporated herein by reference, and in compliance with all applicable federal, state and local laws, regulations, zoning codes, building codes, safety rules, environmental restrictions, ordinances and regulations, including without limitation, the most recent IEEE Standard 1547 Guide for Distributed Generation Interconnection, applicable ANSI standards, including ANSI C84.1 Range A, Electric Reliability Council of Texas (ERCOT) Independent System Operator (ISO) directives and ERCOT guidelines, and in accordance with industry standard prudent engineering practices.

3) Liability Insurance

A Member meeting the standards of this manual shall not be required to purchase any amount, type or classification of liability insurance the Member would not have in the absence of the DG. The Cooperative recommends, however, the Member obtain liability insurance including contractual liability insurance covering indemnity

agreements which insures the Member against all claims for property damage and for personal injury or death arising out of, resulting from or in any manner connected with the installation, operation and maintenance of the Member's generating equipment.

4) Contracts

a) Interconnection Contract

The Member will sign and deliver an Agreement for Interconnection to the Cooperative substantially in the form as shown in the COOPERATIVE AGREEMENT FOR INTERCONNECTION AND PARALLEL OPERATION OF DISTRIBUTED GENERATION included in this Manual.

5) Initial Interconnection

a) Upon satisfactory completion of the review process and execution of required agreements as outlined in this Manual, the Cooperative will begin installation of the interconnection of DG facilities. The interconnection will be completed as soon as practical after completion of the review process and execution of the necessary agreements/contracts. After completion of interconnection requirements and prior to initiation of service, the Cooperative will conduct a final inspection of the facilities and interconnection to the Cooperative's system. Upon satisfactory final inspection, the Cooperative will initiate service to the Member.

b) The Cooperative's review process and final inspection is intended as a means to safeguard the Cooperative's facilities and personnel. The Member acknowledges and agrees that any review or acceptance of such plans, specifications and other information by the Cooperative and/or its Power Supplier shall not impose any liability on the Cooperative and/or its Power Supplier and does not guarantee the adequacy of the Member's equipment or DG facility to perform its intended function. The Cooperative and its Power Supplier disclaims any expertise or special knowledge relating to the design or performance of generating installations and does not warrant the efficiency, cost-effectiveness, safety, durability, or reliability of such DG installations.

VI. REFUSAL TO INTERCONNECT SERVICE OR DISCONNECTION OF INTERCONNECTION SERVICE

The Cooperative may, at its sole discretion, prevent the interconnection or disconnect the interconnection of DG facilities due to reasons such as safety concerns, reliability issues, power quality issues, breach of interconnection contract or any other reasonable issue. Any disconnection may be without prior notice.

VII. OPERATION OF PARALLEL FACILITY

The purpose of this section is to describe the requirements and procedures for safe and effective connection and operation of DG.

- a) The Member may operate a 60 Hertz (Hz) three-phase or single-phase DG facility, in parallel with the Cooperative system pursuant to an interconnection agreement, provided that the equipment meets or exceeds the requirements of this manual.
- b) This manual describes typical interconnection requirements. Certain specific interconnection locations and conditions may require the installation and use of more sophisticated protective devices and operating schemes, especially when the facility is exporting power to the Cooperative system.

1) Self-Protection of DG Facilities

- a) The Member will furnish, install, operate and maintain in good order and repair all equipment necessary for the safe operation of DG facilities operated in parallel with the Cooperative system.
- b) The Member's equipment will have capability to both establish and maintain synchronism with the Cooperative system and to automatically disconnect and isolate the DG facility from the Cooperative system.
- c) The Member's DG facility will be designed, installed and maintained to be self-protected from normal and abnormal conditions on the Cooperative system including, but not limited to, overvoltage, undervoltage, overcurrent, frequency deviation, and faults. Self-protection will be compatible with all applicable Cooperative protection arrangements and operating policies.
- d) Additional protective devices and/or functions may be required by the Cooperative when, in the sole judgment of the Cooperative, the particular DG facility installation and/or the Cooperative system characteristics so warrant.

2) Quality of service

- a) The Member's DG facility will generate power at the nominal voltage of the Cooperative's system at the Member's delivery point as defined by ANSI C84.1 Range A.
- b) Member's DG installation will generate power at a frequency within the tolerances as defined by IEEE 1547.
- c) Member's DG facility shall produce power at a minimum power factor of at least 97% or shall use power factor correction capacitors to ensure at least a 97% power factor.
- d) Member's DG facility shall be in accordance with the power quality limits specified in IEEE 519.
- e) The overall quality of the power provided by the Member's DG facility including, but not limited to, the effects of harmonic distortion, voltage regulation, voltage flicker, switching surges and power factor, will be such that the Cooperative system is not adversely affected in any manner.
- f) In the event that the adverse effects are caused in whole or in part by the Member's DG facility, the Member will correct the cause of such effects within 30 days, reimburse the Cooperative for required correction, or be disconnected from the Cooperative system.

3) Safety disconnect

- a) The Member shall install a visible load break disconnect switch at the Member's expense and to the Cooperative's specifications.
- b) The switch will be located so as to be readily accessible to Cooperative personnel in a location acceptable to both the Member and Cooperative.
- c) The switch shall be a type that can be secured in an open position by a lock owned by the Cooperative. If the Cooperative has locked the disconnect switch open, the Member shall not operate or close the disconnect switch.
- d) The Cooperative shall have the right to lock the switch open when, in the judgment of the Cooperative:
 - (1) It is necessary to maintain safe electrical operating and/or maintenance conditions,
 - (2) The Member's DG adversely affects the Cooperative system, or
 - (3) There is a system emergency or other abnormal operating condition warranting disconnection.
- e) The Cooperative reserves the right to operate the disconnect switch for the protection of the Cooperative system even if it affects the Member's DG facility. In the event the Cooperative opens and/or closes the disconnect switch:
 - (1) The Cooperative shall not be responsible for energization or restoration of parallel operation of the DG facility.
 - (2) The Cooperative will make reasonable efforts to notify the Member.
- f) The Member will not bypass the disconnect switch at any time for any reason.
- g) Signage shall be placed by the Member at the Member's expense and located at the disconnect indicating the purpose of the switch along with contact names and numbers of both the Member and the Cooperative.
- h) Members with DG facilities as defined in this Manual which are solely for the purpose of emergency backup or peak shaving without intent to export power shall not operate their DG facilities at any time unless visibly disconnected from the Cooperative system. At its sole discretion, the Cooperative may require Member to install at his/her own expense an interlocking switch for the purpose of insuring the Member's facilities do not operate in parallel with the Cooperative's facilities.
- i) Should the Cooperative lose power serving the Member's DG facilities for any reason, Members with DG facilities shall not operate their DG facilities unless visibly disconnected from the Cooperative system.

4) Access

- a) Persons authorized by the Cooperative will have the right to enter the Member's property for purposes of testing, operating the disconnect switch, reading or testing the metering equipment, maintaining right-of-way or other DG facility equipment and/or Cooperative service requirement. Such entry onto the Member's property may be without notice.
- b) If the Member erects or maintains locked gates or other barriers, the Member will furnish the Cooperative with convenient means to circumvent the barrier for full access for the above-mentioned reasons.

5) Liability for Injury and Damages

- a) THE MEMBER ASSUMES FULL RESPONSIBILITY FOR ELECTRIC ENERGY FURNISHED AT AND PAST THE POINT OF INTERCONNECTION AND SHALL INDEMNIFY, RELEASE, DEFEND AND HOLD HARMLESS THE COOPERATIVE AND/OR ITS POWER SUPPLIER, AND EACH OF THEIR RESPECTIVE OFFICERS, DIRECTORS, MANAGERS, AGENTS, AND CONTRACTORS (COLLECTIVELY, "INDEMNIFIED PARTIES") FROM AND AGAINST ALL CLAIMS, LIABILITY, LOSSES, DEMANDS, COSTS AND EXPENSES, INCLUDING REASONABLE ATTORNEYS' FEES AND LITIGATION EXPENSES ARISING OUT OF OR RELATED TO ANY INJURIES TO PERSONS, INCLUDING DEATH RESULTING THEREFROM, OR PROPERTY DAMAGE OCCURRING UPON THE PREMISES OWNED OR OPERATED BY MEMBER ("MEMBER PREMISES") ARISING FROM OR IN CONNECTION WITH ELECTRIC POWER AND ENERGY DELIVERED BY THE COOPERATIVE TO THE MEMBER PREMISES OR IN ANY WAY ARISING DIRECTLY OR INDIRECTLY FROM OR RELATED TO THE MEMBER'S DG FACILITY.
- b) **THE INDEMNIFIED PARTIES SHALL NOT BE LIABLE TO THE MEMBER OR ANY THIRD PARTY FOR ANY DIRECT, INDIRECT, CONSEQUENTIAL, INCIDENTAL, SPECIAL, PUNITIVE OR EXEMPLARY DAMAGES (EVEN IF ADVISED OF THE POSSIBILITY OF SUCH DAMAGES) ARISING OUT OF OR RELATED TO (I) LOSS OF ANTICIPATED REVENUE, EARNINGS, PROFITS, OR INCREASED EXPENSE OF OPERATIONS, LOSS BY REASON OF SHUTDOWN OR NON-OPERATION OF MEMBER'S PREMISES OR FACILITIES OR (II) FAILURES, INTERRUPTIONS, OR VOLTAGE AND WAVEFORM FLUCTUATIONS OCCASIONED BY CAUSES REASONABLY BEYOND THE CONTROL OF THE INDEMNIFIED PARTIES INCLUDING, BUT NOT LIMITED TO, ACTS OF GOD OR PUBLIC ENEMY, SABOTAGE AND/OR VANDALISM, ACCIDENTS, FIRE, EXPLOSION, LABOR TROUBLES, STRIKES, ORDER OF ANY COURT OR JUDGE GRANTED IN ANY BONA FIDE ADVERSE LEGAL PROCEEDING OR ACTION, OR ANY ORDER OF ANY COMMISSION, TRIBUNAL OR GOVERNMENTAL AUTHORITY HAVING JURISDICTION.**
- c) The Member is solely responsible for insuring his/her facility complies with all applicable regulations including, but not limited to, laws, regulations, ordinances, Cooperative and Cooperative Power Supplier tariffs, policies and directives, and ERCOT rules, policies and directives.

6) Metering/Monitoring

- a) The Cooperative shall supply, own and maintain all necessary meters and associated equipment to record energy purchases by the Member and energy exports to the Cooperative system.
- b) The Member shall supply at no cost to the Cooperative a suitable location on his or her premises for the installation of the Cooperative's meters and other equipment.
- c) The facility will be metered by installing a single meter with two registers capable of measuring in-flow and out-flow at the point of delivery of electric service.
- d) The Cooperative may, at its sole discretion, install a separate meter that measures the output of the DG facility.
- e) The meter shall be read at a time or times of month determined at the Cooperative's sole discretion for acquiring metering data.
- f) The Cooperative may, at its sole discretion, require the Member to pay the Cooperative in advance for metering and monitoring equipment and installation expense.
- g) Meter testing shall follow the Cooperative's standard policy on metering testing and accuracy.

7) Notice of Change in Installation

- a) The Member will notify the Cooperative in writing thirty (30) days in advance of making any change affecting the characteristics, performance, or protection of the DG facility.
- b) If any modification undertaken by the Member will create or has created conditions which may be unsafe or adversely affect the Cooperative system, the Member shall immediately correct such conditions or be subject to immediate disconnection from the Cooperative system.
- c) Any change in the operating characteristics of the DG facility including, but not limited to, size of generator, total facility capacity, nature of facility, fuel source, site change, hours of operation, or type used, may require a new application process, including, but not limited to, application form, application fee, DG plan and DG plan review by the Cooperative.

8) Testing and Record Keeping

- a) The Member will test all aspects of the protection systems up to and including tripping of the generator and interconnection point at start-up and thereafter as required. Testing will verify all protective set points and relay/breaker trip timing and shall include procedures to functionally test all protective elements of the system. The Cooperative may witness the testing.
- b) The Member will maintain records of all maintenance activities, which the Cooperative may review at reasonable times.

9) Disconnection of Service

The Cooperative may, at its sole discretion, discontinue the interconnection of DG installations due to reasons such as safety concerns, reliability issues, power quality issues, breach of interconnection contract or any other reasonable issue.

11) Compliance with Laws, Rules and Tariffs

The DG installation owned and installed by the Member shall be installed and operated subject to and in accordance with the terms and conditions set forth in the Cooperative's rules, regulations, bylaws, rates and tariffs, as amended from time to time, and, if applicable, approved by the Cooperative's board of directors, which are incorporated herein by reference, and in compliance with all applicable federal, state and local laws, regulations, zoning codes, building codes, safety rules, environmental restrictions, ordinances and regulations, including without limitation, Electric Reliability Council of Texas (ERCOT) Independent System Operator (ISO) directives and ERCOT guidelines, and in accordance with industry standard prudent engineering practices.

**KARNES ELECTRIC COOPERATIVE, INC.
AGREEMENT FOR INTERCONNECTION AND PARALLEL OPERATION OF DISTRIBUTED
GENERATION**

**SHORT FORM CONTRACT
APPLICABLE FOR LOADS LESS THAN OR EQUAL TO 50 KW IN SIZE AND OF STANDARD
MANUFACTURE AND DESIGN**

This Interconnection Agreement ("Agreement") is made and entered into this ____ day of _____, 20____, by Karnes Electric Cooperative, Inc., ("Cooperative"), a corporation organized under the laws of the State of Texas, and _____ ("DG Owner/Operator"), each hereinafter sometimes referred to individually as "Party" or both referred to collectively as the "Parties". In consideration of the mutual covenants set forth herein, the Parties agree as follows:

The provisions of the Cooperative's Distributed Generation Manual shall be considered to be a part of this contract.

This agreement provides for the safe and orderly operation of the electrical facilities interconnecting the DG Owner/Operator's facility at _____

_____ (as further described in Exhibit A) and the electrical distribution facility owned by the Cooperative.

This Agreement does not supersede any requirements of any applicable tariffs in place between the DG Owner/Operator and the Cooperative.

1. **Intent of Parties:** It is the intent of the DG Owner/Operator to interconnect an electric power generator to the Cooperative's electrical distribution system.

It is the intent of the Cooperative to operate the distribution system to maintain a high level of service to their customers and to maintain a high level of power quality.

It is the intent of both parties to operate the facilities in a way that ensures the safety of the public and their employees.

2. **Establishment of Point of Interconnection** - The point where the electric energy first leaves the wires or facilities owned by the Cooperative and enters the wires or facilities provided by DG Owner/Operator is the "Point of Interconnection." Cooperative and DG Owner/Operator agree to interconnect the Facilities at the Point of Interconnection in accordance with the Cooperative's Rules and Regulations and DG Manual relating to interconnection of Distributed Generation (the "Rules") and as described in the attached Exhibit A. The interconnection equipment installed by the customer ("Interconnection Facilities") shall be in accordance with the Rules as well.

3. **Operating authority:** The DG Owner/Operator is responsible for establishing operating procedures and standards within their organization. The operating authority for the DG Owner/Operator shall ensure that the Operator in Charge of the generator is competent in the operation of the electrical generation system and is aware of the provisions of any operating agreements and regulations relating to the safe operation of electrical power systems.

The operating authority for the DG Owner/Operator is:

Name or title of operating authority _____
Address _____
Phone number _____

4. **Operator in Charge:** The operator in charge is the person identified by name or job title responsible for the real time operation of all electrical facilities related to the interconnection and owned by their organization.

The operator in charge for the DG Owner/Operator is:

Name or title of operating authority _____
Address _____
Phone number _____

5. **ASSUMPTION OF LIABILITY; INDEMNIFICATION: DG OWNER/OPERATOR ASSUMES ENTIRE RESPONSIBILITY AND LIABILITY FOR ANY CLAIM OR ACTIONS BASED ON OR ARISING OUT OF INJURIES, INCLUDING DEATH, TO PERSONS OR DAMAGES TO OR DESTRUCTION OF PROPERTY, SUSTAINED OR ALLEGED TO HAVE BEEN SUSTAINED IN CONNECTION WITH OR TO HAVE ARISEN OUT OF OR INCIDENTAL TO THE PERFORMANCE OF THIS CONTRACT BY DG OWNER/OPERATOR, ITS AGENTS AND EMPLOYEES, AND ITS SUBCONTRACTORS, THEIR AGENTS AND EMPLOYEES, REGARDLESS OF WHETHER SUCH CLAIMS OR ACTIONS ARE FOUNDED IN WHOLE OR IN PART UPON ALLEGED NEGLIGENCE OF OWNER, KARNES ELECTRIC COOPERATIVE INC., KARNES ELECTRIC COOPERATIVE'S REPRESENTATIVES, OR EACH OF THEIR RESPECTIVE OFFICERS, DIRECTORS, MANAGERS, EMPLOYEES, AGENTS, INVITEES, OR LICENSEES (COLLECTIVELY, THE "KEC PARTIES"). DG OWNER/OPERATOR, FURTHER AGREES TO INDEMNIFY, DEFEND AND HOLD HARMLESS THE KEC PARTIES FROM AND AGAINST ALL CLAIMS, LIABILITY, LOSSES, DEMANDS, COSTS AND EXPENSES, INCLUDING REASONABLE ATTORNEYS' FEES AND LITIGATION EXPENSES ARISING OUT OF OR RELATED TO ANY INJURIES TO PERSONS, INCLUDING DEATH RESULTING THEREFROM, OR PROPERTY DAMAGE OCCURRING UPON THE PREMISES OF DG OWNER/OPERATOR ARISING FROM OR IN CONNECTION WITH ELECTRIC POWER AND ENERGY DELIVERED BY THE KEC PARTIES TO DG OWNER/OPERATOR OR IN ANY WAY ARISING DIRECTLY OR INDIRECTLY FROM OR RELATED TO THE DG FACILITY.**

6. **Metering:** Metering shall be accomplished as described in the Cooperative's DG Manual.

7. **Insurance:** Insurance shall be required as described in the Cooperative's DG Manual.

8. **Suspension of Interconnection:** It is intended that the interconnection should not compromise the Cooperative's protection or operational requirements. The operation of the DG Owner/Operator's System and the quality of electric energy supplied by the DG Owner/Operator shall meet the standards as specified by the Cooperative. If the operation of the DG Owner/Operator's system or quality of electric energy supplied (in the case of power export) does not meet the standards as specified, then (the Cooperative) will notify the DG Owner/Operator to take reasonable and expedient corrective action. The Cooperative shall have the right to disconnect the DG Owner/Operator's System, until compliance is reasonably demonstrated. Notwithstanding, the Cooperative may in its sole discretion disconnect the DG Owner/Operator's generating plant from the Distribution Facility without notice if the operating of the Generating Plant may be or may become dangerous to life and property.

9. **Compliance with Laws, Rules and Tariffs:** Both the Cooperative and the DG Owner/Operator shall be responsible for complying with all applicable laws, rules and regulations, including but not limited to the laws of the state of Texas, and the Cooperative's DG Manual, Tariffs, Rules and Regulations, By-Laws and other governing documents. The interconnection and services provided under this Agreement shall at all times be subject to the terms and conditions set forth in the tariff schedules and rules of the Cooperative as applicable to the electric service provided by the Cooperative, which tariffs and rules are hereby incorporated into this Agreement by this reference. The Cooperative shall have the right to publish changes in rates, classification, service or rule, with the proper notification to all DG owners/operators and Cooperative members.

10. **Maintenance Outages:** Maintenance outages will occasionally be required on the Cooperative's system, and the Cooperative will provide as much notice and planning as possible to minimize downtime. It is noted that in some emergency cases such notice may not be possible. Compensation will not be made for unavailability of Cooperative's facilities due to outages.

11. **Access:** Access is required by the Cooperative to the DG Owner/Operator's plant site for maintenance, operating and meter reading. The Cooperative reserves the right, but not the obligation, to inspect the DG Owner/Operator's facilities.

12. **Force Majeure:** For the purposes of this Agreement, a Force Majeure event is any event: (a) that is beyond the reasonable control of the affected party; and (b) that the affected party is unable to prevent or provide against by exercising reasonable diligence, including the following events or circumstances, but only to the extent that they satisfy the preceding requirements: acts of war, public disorder, rebellion or insurrection; floods, hurricanes, earthquakes, lightning, storms or other natural calamities; explosions or fires; strikes, work stoppages or labor disputes; embargoes; and sabotage. If a Force Majeure event prevents a party from fulfilling any obligations under this agreement, such party will promptly notify the other party in writing and will keep the other party informed on a continuing basis as to the scope and duration of the Force Majeure event. The affected party will specify the circumstances of the Force Majeure event, its expected duration and the steps that the affected party is taking to mitigate the effect of the event on its performance. The affected party will be entitled to suspend or modify its performance of obligations under this Agreement but will use reasonable efforts to resume its performance as soon as possible.

13. **Assignment:** At any time during the term of this Agreement, the DG Owner/Operator may assign this Agreement to a corporation, an entity with limited liability or an individual (the "Assignee"), provided that the DG Owner/Operator obtains the consent of the Cooperative in advance of the assignment. The Cooperative's consent will be based on a determination that

the Assignee is financially and technically capable to assume ownership and/or operation of the DG unit. The company or individual to which this Agreement is assigned will be responsible for the proper operation and maintenance of the unit, and will be a party to all provisions of this Agreement.

14. Effective Term and Termination Rights: This Agreement becomes effective when executed by both Parties and shall continue in effect until terminated. This agreement may be terminated as follows: (a) DG Owner/Operator may terminate this Agreement at any time by giving the Cooperative sixty days' written notice; (b) Cooperative may terminate upon failure by the DG Owner/Operator to generate energy from the Facilities in parallel within six (6) months after completion of the interconnection; (c) either Party may terminate by giving the other Party at least thirty (30) days prior written notice that the other Party is in default of any of the terms and conditions of the Agreement or the Rules or any rate schedule, tariff, regulation, contract, or policy of the Cooperative, so long as the notice specifies the basis for termination and there is opportunity to cure the default; (d) Cooperative may terminate by giving DG Owner/Operator at least sixty (60) days written notice in the event that there is a material change in an applicable law, or any requirement of the Cooperative's wholesale electric suppliers or any transmission utility, independent system operator or regional transmission organization having responsibility for the operation of any part of the System.

AGREED TO BY

DG Owner/Operator

Karnes Electric Cooperative, Inc.

Name

Name

Title

Title

Date

Date

EXHIBIT A
DESCRIPTION OF FACILITIES AND POINT OF INTERCONNECTION

DG Owner/Operator will, at its own cost and expense, operate, maintain, repair, and inspect, and shall be fully responsible for its Facilities, unless otherwise specified on Exhibit A

**KARNES ELECTRIC COOPERATIVE, INC.
AGREEMENT FOR INTERCONNECTION AND PARALLEL OPERATION OF DISTRIBUTED
GENERATION**

**LONG FORM CONTRACT
APPLICABLE FOR LOADS GREATER THAN 50 KW AND/OR NOT OF STANDARD
MANUFACTURE AND DESIGN**

This Interconnection Agreement ("Agreement") is made and entered into this ____ day of _____, 20____, by Karnes Electric Cooperative, Inc., ("Cooperative"), a corporation organized under the laws of the State of Texas, and _____ ("DG Owner/Operator"), each hereinafter sometimes referred to individually as "Party" or both referred to collectively as the "Parties." In consideration of the mutual covenants set forth herein, the Parties agree as follows:

1. Scope of Agreement - This Agreement is applicable to conditions under which the Cooperative and the DG Owner/Operator agree that one or more generating facilities (described in Exhibit A) owned by the DG Owner/Operator of _____ kW or less, to be interconnected at _____ kV or less ("Facilities") may be interconnected to the Cooperative's electric power distribution system ("System").

The provisions of the Cooperative's Distributed Generation Manual shall be considered to be a part of this contract.

2. Establishment of Point of Interconnection - The point where the electric energy first leaves the wires or facilities owned by the Cooperative and enters the wires or facilities provided by DG Owner/Operator is the "Point of Interconnection." Cooperative and DG Owner/Operator agree to interconnect the Facilities at the Point of Interconnection in accordance with the Cooperative's Rules and Regulations and DG Manual relating to interconnection of Distributed Generation (the "Rules") and as described in the attached Exhibit A. The interconnection equipment installed by the customer ("Interconnection Facilities") shall be in accordance with the Rules as well.

3. Responsibilities of Cooperative and DG Owner/Operator for Installation, Operation and Maintenance of Facilities - DG Owner/Operator will, at its own cost and expense, operate, maintain, repair, and inspect, and shall be fully responsible for, its Facilities, unless otherwise specified on Exhibit A. DG Owner/Operator shall conduct operations of its Facilities in compliance with all aspects of the Rules, and Cooperative shall conduct operations of its electric distribution facilities in compliance with all aspects of the Rules, or as further described and mutually agreed to in the applicable Facilities Schedule. Maintenance of Interconnection Facilities shall be performed in accordance with the applicable manufacturers' recommended maintenance schedule. The DG Owner/Operator agrees to cause its Interconnection Facilities to be constructed in accordance with specifications equal to or better than those provided by the National Electrical Safety Code and the National Electrical Code, both codes approved by the American National Standards Institute, in effect at the time of construction.

The DG Owner/Operator covenants and agrees to cause the design, installation, maintenance, and operation of, its Interconnection Facilities so as to reasonably minimize the likelihood of a malfunction or other disturbance, damaging or otherwise affecting or impairing the System. DG Owner/Operator shall comply with all applicable laws, regulations, zoning codes, building codes, safety

rules and environmental restrictions applicable to the design, installation and operation of its Facilities.

Cooperative will notify DG Owner/Operator if there is evidence that the Facilities' operation causes disruption or deterioration of service to other customer(s) served from the System or if the Facilities' operation causes damage to the System. DG Owner/Operator will notify the Cooperative of any emergency or hazardous condition or occurrence with the DG Owner/Operator's Facilities, which could affect safe operation of the System.

4. **Operator in Charge** - The Cooperative and the DG Owner/Operator shall each identify an individual (by name or title) who will perform as "Operator in Charge" of the facilities and their section of the Interconnection Facilities. This individual must be familiar with this Agreement as well as provisions of other agreements and any regulations that may apply.

5. ASSUMPTION OF LIABILITY; INDEMNIFICATION: DG OWNER/OPERATOR ASSUMES ENTIRE RESPONSIBILITY AND LIABILITY FOR ANY CLAIM OR ACTIONS BASED ON OR ARISING OUT OF INJURIES, INCLUDING DEATH, TO PERSONS OR DAMAGES TO OR DESTRUCTION OF PROPERTY, SUSTAINED OR ALLEGED TO HAVE BEEN SUSTAINED IN CONNECTION WITH OR TO HAVE ARISEN OUT OF OR INCIDENTAL TO THE PERFORMANCE OF THIS CONTRACT BY DG OWNER/OPERATOR, ITS AGENTS AND EMPLOYEES, AND ITS SUBCONTRACTORS, THEIR AGENTS AND EMPLOYEES, REGARDLESS OF WHETHER SUCH CLAIMS OR ACTIONS ARE FOUNDED IN WHOLE OR IN PART UPON ALLEGED NEGLIGENCE OF OWNER, KARNES ELECTRIC COOPERATIVE INC., KARNES ELECTRIC COOPERATIVE'S REPRESENTATIVES, OR EACH OF THEIR RESPECTIVE OFFICERS, DIRECTORS, MANAGERS, EMPLOYEES, AGENTS, INVITEES, OR LICENSEES (COLLECTIVELY, THE "KEC PARTIES"). DG OWNER/OPERATOR, FURTHER AGREES TO INDEMNIFY, DEFEND AND HOLD HARMLESS THE KEC PARTIES FROM AND AGAINST ALL CLAIMS, LIABILITY, LOSSES, DEMANDS, COSTS AND EXPENSES, INCLUDING REASONABLE ATTORNEYS' FEES AND LITIGATION EXPENSES ARISING OUT OF OR RELATED TO ANY INJURIES TO PERSONS, INCLUDING DEATH RESULTING THEREFROM, OR PROPERTY DAMAGE OCCURRING UPON THE PREMISES OF DG OWNER/OPERATOR ARISING FROM OR IN CONNECTION WITH ELECTRIC POWER AND ENERGY DELIVERED BY THE KEC PARTIES TO DG OWNER/OPERATOR OR IN ANY WAY ARISING DIRECTLY OR INDIRECTLY FROM OR RELATED TO THE DG FACILITY.

6. **Design Reviews and Inspections** - The DG Owner/Operator shall provide to the Cooperative the following documentation and inspection results:

- a. One-Line Diagram. The diagram shall include at a minimum, all major electrical equipment that is pertinent to understanding the normal and contingency operations of the DG Interconnection Facilities, including generators, switches, circuit breakers, fuses, protective relays and instrument transformers.
- b. Testing Records. Testing of protection systems shall be limited to records of compliance with standard acceptance procedures and by industry standards and practices. These records shall include testing at the start of commercial operation and periodic testing thereafter.

7. Right of Access, Equipment Installation, Removal & Inspection - The Cooperative may send an employee, agent or contractor to the premises of the DG Owner/Operator at any time whether before, during or after the time the Facilities first produces energy to inspect the Interconnection Facilities, and observe the Facility's installation, commissioning (including any testing), startup, and operation.

At all times Cooperative shall have access to DG Owner/Operator's premises for any reasonable purpose in connection with the interconnection described in this Agreement, the Rules, or to provide service to its customers.

8. Confidentiality of Information - Unless compelled to disclose by judicial or administrative process, or by other provisions of law or as otherwise provided for in this Agreement, the DG Owner/Operator and the Cooperative will hold in confidence any and all documents and information furnished by the other party in connection with this Agreement.

9. Prudent Operation and Maintenance Requirements - The DG Owner/Operator shall operate and maintain its generation and interconnection facilities in accordance with industry standard prudent electrical practices. The said standards shall be those in effect at the time a DG Owner/Operator executes an interconnection agreement with the Cooperative.

10. Disconnection of Unit - DG Owner/Operator retains the option to disconnect its Facilities from the System, provided that DG Owner/Operator notifies the Cooperative of its intent to disconnect by giving the Cooperative at least thirty (30) days' prior written notice. Such disconnection shall not be a termination of the agreement unless DG Owner/Operator exercises rights under Section 13.

DG Owner/Operator shall disconnect Facilities from the System upon the effective date of any termination under Section 13.

Subject to the Rules, for routine maintenance and repairs on the System, Cooperative shall provide DG Owner/Operator with seven (7) business days' notice of service interruption.

Cooperative shall have the right to suspend service in cases where continuance of service to DG Owner/Operator will endanger persons or property. During the forced outage of the System serving DG Owner/Operator, Cooperative shall have the right to suspend service to effect repairs on the System, but the Cooperative shall use its efforts to provide the DG Owner/Operator with reasonable prior notice.

11. Metering - Metering shall be accomplished as described in the Cooperative's DG Manual.

12. Insurance – Insurance shall be required as described in the Cooperative's DG Manual.

13. Effective Term and Termination Rights - This Agreement becomes effective when executed by both Parties and shall continue in effect until terminated. This agreement may be terminated as follows: (a) DG Owner/Operator may terminate this Agreement at any time by giving the Cooperative sixty days' written notice; (b) Cooperative may terminate upon failure by the DG Owner/Operator to generate energy from the Facilities in parallel within six (6) months after completion of the interconnection; (c) either Party may terminate by giving the other Party at least thirty (30) days prior written notice that the other Party is in default of any of the terms and conditions of the Agreement or the Rules or any rate schedule, tariff, regulation, contract, or policy of the

Cooperative, so long as the notice specifies the basis for termination and there is opportunity to cure the default; (d) Cooperative may terminate by giving DG Owner/Operator at least sixty (60) days written notice in the event that there is a material change in an applicable law, or any requirement of the Cooperative's wholesale electric suppliers or any transmission utility, independent system operator or regional transmission organization having responsibility for the operation of any part of the System.

14. Dispute Resolution - THE PARTIES EACH HEREBY UNCONDITIONALLY AND IRREVOCABLY SUBMIT TO THE EXCLUSIVE JURISDICTION OF, AND AGREE EXCLUSIVE VENUE SHALL LIE IN, THE STATE COURTS LOCATED IN KARNES COUNTY, TEXAS, AND THE FEDERAL COURTS OF THE UNITED STATES OF AMERICA FOR THE SOUTHERN DISTRICT OF TEXAS.

15. Compliance with Laws, Rules and Tariffs - Both the Cooperative and the DG Owner/Operator shall be responsible for complying with all applicable laws, rules and regulations, including but not limited to the laws of the state of _____, and the Cooperative's DG Manual, Tariffs, Rules and Regulations, By-Laws and other governing documents. The interconnection and services provided under this Agreement shall at all times be subject to the terms and conditions set forth in the tariff schedules and rules of the Cooperative as applicable to the electric service provided by the Cooperative, which tariffs and rules are hereby incorporated into this Agreement by this reference. The Cooperative shall have the right to publish changes in rates, classification, service or rule, with the proper notification to all DG owners/operators and Cooperative members.

16. Severability -If any portion or provision of this Agreement is held or adjudged for any reason to be invalid or illegal or unenforceable by any court of competent jurisdiction, such portion shall be deemed separate and independent, and the remainder of this Agreement shall remain in full force and effect.

17. Amendment - This Agreement may be amended only upon mutual agreement of the Parties, which amendment will not be effective until reduced to writing and executed by the Parties.

18. Entirety of Agreement and Prior Agreements Superseded - This Agreement, including the Rules and all attached Exhibits and Facilities Schedules, which are expressly made a part hereof for all purposes, constitutes the entire agreement and understanding between the Parties with regard to the interconnection of the facilities of the Parties at the Points of Interconnection expressly provided for in this Agreement. The Parties are not bound by or liable for any statement, representation, promise, inducement, understanding, or undertaking of any kind or nature (whether written or oral) with regard to the subject matter hereof not set forth or provided for herein or in the DG Owner/Operator application, or other written information provided by the DG Owner/Operator in compliance with the Rules. It is expressly acknowledged that the Parties may have other agreements covering other services not expressly provided for herein, which agreements are unaffected by this Agreement.

19. Force Majeure -For the purposes of this Agreement, a Force Majeure event is any event: (a) that is beyond the reasonable control of the affected party; and (b) that the affected party is unable to prevent or provide against by exercising reasonable diligence, including the following events or circumstances, but only to the extent that they satisfy the preceding requirements: acts of war, public disorder, rebellion or insurrection; floods, hurricanes, earthquakes, lighting,

storms or other natural calamities; explosions or fires; strikes, work stoppages or labor disputes; embargoes; and sabotage. If a Force Majeure event prevents a party from fulfilling any obligations under this agreement, such party will promptly notify the other party in writing and will keep the other party informed on a continuing basis as to the scope and duration of the Force Majeure event. The affected party will specify the circumstances of the Force Majeure event, its expected duration and the steps that the affected party is taking to mitigate the effect of the event on its performance. The affected party will be entitled to suspend or modify its performance of obligations under this Agreement but will use reasonable efforts to resume its performance as soon as possible.

20. **Assignment** - At any time during the term of this Agreement, the DG Owner/Operator may assign this Agreement to a corporation, an entity with limited liability or an individual (the "Assignee"), provided that the DG Owner/Operator obtains the consent of the Cooperative in advance of the assignment. The Cooperative's consent will be based on a determination that the Assignee is financially and technically capable to assume ownership and/or operation of the DG unit. The company or individual to which this Agreement is assigned will be responsible for the proper operation and maintenance of the unit, and will be a party to all provisions of this Agreement.

21. **Permits, Fees and Approvals** - The Cooperative will have responsibility for the review, approval or rejection of the DG interconnection application. The approval process is intended to ensure that the implementation of the applicant's DG project will not adversely affect the safe and reliable operation of the Cooperative's System. The fees associated with the Application are listed in the most current fee schedule issued by the Cooperative. All fees are to be submitted in the form of a Bank Cashier's check along with the Application, unless other payment terms have been approved in advance by the Cooperative.

22. **Notices** - Notices given under this Agreement are deemed to have been duly delivered if hand delivered or sent by United States certified mail, return receipt requested, postage prepaid, to:

(a) If to Cooperative:

(b) If to DG Owner/Operator:

The above-listed names, titles, and addresses of either Party may be changed by written notification to the other, notwithstanding Section 17.

23. **Invoicing and Payment** - Invoicing and payment terms for services associated with this Agreement shall be consistent with applicable Rules of the Cooperative.

24. **Limitations (No Third-Party Beneficiaries, Waiver, etc.)** - This Agreement is not intended to, and does not create, rights, remedies, or benefits of any character whatsoever in favor of any persons, corporations, associations, or entities other than the Parties, and the obligations herein assumed are solely for the use and benefit of the Parties. This Agreement may not be assigned by the DG Owner/Operator without the prior written consent of the Cooperative as specified in Section 20. The failure of a Party to this Agreement to insist, on any occasion, upon strict performance of any provision of this Agreement will not be considered to waive the obligations, rights, or duties imposed upon the Parties.

25. **Headings** - The descriptive headings of the various articles and sections of this Agreement have been inserted for convenience of reference only and are to be afforded no significance in the interpretation or construction of this Agreement.

26. **Multiple Counterparts** - This Agreement may be executed in two or more counterparts, each of which is deemed an original but all constitute one and the same instrument.

IN WITNESS WHEREOF, the Parties have caused this Agreement to be signed by their respective duly authorized representatives.

Karnes Electric Cooperative, Inc.

[DG OWNER/OPERATOR NAME]

BY: _____

BY: _____

TITLE: _____

TITLE: _____

DATE: _____

DATE: _____

EXHIBIT A
DESCRIPTION OF FACILITIES AND POINT OF INTERCONNECTION

DG Owner/Operator will, at its own cost and expense, operate, maintain, repair, and inspect, and shall be fully responsible for its Facilities, unless otherwise specified on Exhibit A

KARNES ELECTRIC COOPERATIVE, INC.

Application for Operation of Customer-Owned Generation

This application should be completed as soon as possible and returned to the Cooperative Customer Service representative in order to begin processing the request. See *Distributed Generation Procedures and Guidelines Manual for Members* for additional information.

INFORMATION: *This application is used by the Cooperative to determine the required equipment configuration for the Customer interface. Every effort should be made to supply as much information as possible.*

**PART 1
MEMBER/APPLICANT INFORMATION**

Member: _____
Mailing Address: _____
City: _____ County: _____ State: _____ Zip Code: _____
Phone Number: _____ KEC Account #: _____
Representative: _____

PROJECT DESIGN/ENGINEERING (as applicable)

Company: _____
Mailing Address: _____
City: _____ County: _____ State: _____ Zip Code: _____
Phone Number: _____ Representative: _____

ELECTRICAL CONTRACTOR (as applicable)

Company: _____
Mailing Address: _____
City: _____ County: _____ State: _____ Zip Code: _____
Phone Number: _____ Representative: _____

TYPE OF GENERATOR (as applicable)

Photovoltaic _____ Wind _____ Microturbine _____
Diesel Engine _____ Gas Engine _____ Turbine Other _____

PART 2

(Complete all applicable items. Copy this page as required for additional generators.)

SYNCHRONOUS GENERATOR DATA

Unit Number: _____ Total number of units with listed specifications on site: _____

Manufacturer: _____

Type: _____ Date of manufacture: _____

Serial Number (each): _____

Phases: Single ____ Three ____ R.P.M.: _____ Frequency (Hz): _____

Rated Output (for one unit): _____ Kilowatt _____ Kilovolt-Amper _____

Rated Power Factor (%): _____ Rated Voltage (Volts) _____ Rated Amperes: _____

Field Volts: _____ Field Amps: _____ Motoring power (kW): _____

Synchronous Reactance (X'd): _____ % on _____ KVA base

Transient Reactance (X'd): _____ % on _____ KVA base

Subtransient Reactance (X'd): _____ % on _____ KVA base

Negative Sequence Reactance (Xs): _____ % on _____ KVA base

Zero Sequence Reactance (Xo): _____ % on _____ KVA base

Neutral Grounding Resistor (if applicable): _____

I_2^2t of K (heating time constant): _____

Additional Information: _____

INDUCTION GENERATOR DATA

Rotor Resistance (Rr): _____ ohms Stator Resistance (Rs): _____ ohms

Rotor Reactance (Xr): _____ ohms Stator Reactance (Xs): _____ ohms

Magnetizing Reactance (Xm): _____ ohms Short Circuit Reactance (Xd''): _____ ohms

Design letter: _____ Frame Size: _____

Exciting Current: _____ Temp Rise (deg C°): _____

Reactive Power Required: _____ Vars (no load), Vars _____ (full load)

Additional Information: _____

PRIME MOVER (Complete all applicable items)

Unit Number: _____ Type: _____

Manufacturer: _____

Serial Number: _____ Date of manufacturer: _____

H.P. Rates: _____ H.P. Max.: _____ Inertia Constant: _____ lb.-ft²

Energy Source (hydro, steam, wind, etc.) _____

GENERATOR TRANSFORMER (Complete all applicable items)

TRANSFORMER (between generator and utility system)

Generator unit number: _____ Date of manufacturer: _____

Manufacturer: _____

Serial Number: _____

High Voltage: _____ KV, Connection: delta wye, Neutral solidly grounded? _____

Low Voltage: _____ KV, Connection: delta wye, Neutral solidly grounded? _____

Transformer Impedance (Z): _____ % on _____ KVA base

Transformer Resistance (R): _____ % on _____ KVA base

Transformer Reactance (X): _____ % on _____ KVA base

Neutral Grounding Resistor (if applicable: _____

INVERTER DATA (if applicable)

Manufacturer: _____ Model: _____

Rate Power Factor (%): _____ Rated Voltage (Volts): _____ Rated Amperes: _____

Inverter Type (ferroresonant, step, pulse-width modulation, etc.): _____

Type commutation: forced line

Harmonic Distortion: Maximum Single Harmonic (%) _____

Maximum Total Harmonic (%) _____

Note: Attach all available calculations, test reports, and oscillographic prints showing inverter output voltage and current waveforms.

POWER CIRCUIT BREAKER (if applicable)

Manufacturer: _____ Model: _____

Rated Voltage (*kilovolts*): _____ Rated ampacity (*Amperes*) _____

Interrupting rating (Amperes): _____ BIL Rating _____

Interrupting medium / insulating medium (ex. Vacuum, gas, oil) _____ / _____

Control Voltage (Closing): ____ (Volts) AC DC

Control Voltage (Tripping): ____ (Volts) AC DC Battery Charged Capacitor

Close energy: Spring Motor Hydraulic Pneumatic Other: _____

Trip energy: Spring Motor Hydraulic Pneumatic Other: _____

Bushing Current Transformers: _____ (Max. ratio) Relay Accuracy Class: _____

Multi Ratio? No Yes: (available taps) _____

ADDITIONAL INFORMATION

In addition to the items listed above, please attach a detailed one-line diagram of the proposed facility, all applicable elementary diagrams, major equipment (generators, transformers, inverters, circuit breakers, protective relays, etc.), specifications, test reports, etc., and any other applicable drawings or documents necessary for the proper design of the interconnection.

SIGN OFF AREA

The customer agrees to provide the Cooperative with any additional information required to complete the interconnection. The customer shall operate his equipment within the guidelines set forth by the Cooperative.

Applicant

Date

ELECTRIC COOPERATIVE CONTACT FOR APPLICATION SUBMISSION AND FOR MORE INFORMATION:

Cooperative contact: _____

Title: _____

Address: _____

Phone: _____

Fax: _____

Karnes Electric Cooperative, Inc.

Distributed Generation Rider

Application

Applicable to Distributed Generation Facilities smaller than 700 kW of connected generation connected in parallel operation to the Cooperative's electric system in accordance with the Cooperative's service rules and regulations and the Cooperative's *Distributed Generation Procedures and Guidelines Manual for Members* (available on request).

This rate is not applicable to temporary, shared, or resale service. This rate is applicable to service supplied at one point of delivery.

Sales to Member

Sales to a Distributed Generation Customer shall be consistent with the applicable retail rate tariff established by the Cooperative and in use by the Member as if there were no Distributed Generation installation.

Purchases from a Member – Facility classified as 50 kW of connected generation and smaller

Determination of billing shall be accomplished by interconnection through one meter with two registers capable of measuring in-flow and out-flow at the point of delivery of electric service.

When the energy supplied by the Cooperative exceeds the energy supplied by the Member during a billing period, the net energy (kWh) supplied by the Cooperative to the Member, shall be billed by the Cooperative in accordance with the rates and charges under the cooperative's applicable rate schedule.

When the energy supplied by the Member exceeds the energy supplied by the Cooperative during a billing period, the monthly charge and/or minimum of the retail rate schedule shall be billed, and the excess energy (kWh) generated by the Member and delivered back to the Cooperative, within the billing period, shall be credited to the Member at the Cooperative's Monthly Avoided Cost Rate provided by the Cooperative's wholesale power supplier. If credits for excess energy are greater than the member's monthly bill, the credit will be carried forward to the following billing period. If a credit balance remains at the end of the calendar year, a refund of the entire credit balance will be provided to the member.

Monthly banking of energy (kWh) supplied by the Member, exceeding the energy supplied by the Cooperative during a billing period, will not be allowed.

Any renewable energy credits (REC's) resulting from the operation of the DG are the property of the DG Member unless sold or otherwise transferred by the Member.

Purchases from a Member – Facility classified as greater than 50 kW and less than 700 kW of connected generation

Determination of billing shall be accomplished by interconnection through one meter with two registers capable of measuring in-flow and out-flow at the point of delivery of electric service.

All energy (kWh) supplied by the Cooperative to the Member, during the billing period, shall be billed by the Cooperative in accordance with the rates and charges under the cooperative's applicable rate schedule for the Member.

There will be no netting of energy (kWh). All excess energy (kWh) generated by the Member's qualifying facility during the billing period, not consumed instantaneously by the Member, and delivered back to the Cooperative within the billing period, shall be credited to the Member at the Cooperative's Monthly Avoided Cost Rate provided by the Cooperative's wholesale power supplier. If credits for excess energy are greater than the member's monthly bill, the credit will be carried forward to the following billing period. If a credit balance remains at the end of the calendar year, a refund of the entire credit balance will be provided to the member.

In addition to all other charges, the Cooperative may bill the Member for any additional facilities charges as determined by the Cooperative and appended to the Interconnection Agreement.

Any renewable energy credits (REC's) resulting from the operation of the DG are the property of the DG Member unless sold or otherwise transferred by the Member.

Contracts

An Interconnection Agreement between the Member and the Cooperative shall be required in all cases.

KARNES ELECTRIC COOPERATIVE, INC.

200 AMPERE 120/240 VOLT
DISTRIBUTED GENERATION (25 KVA OR LESS)

DATE: 08-01-16

KARNES CITY OFFICE (830)780-3952

PLEASANTON OFFICE (830)569-5538

COOPERATIVE FURNISHED, OWNED AND INSTALLED

- (A) - MINIMUM 25 FT. METER POLE PROVIDED BY KEC SET 5 FT. DEEP
- (B) - SERVICE ATTACHMENT PROVIDED BY KEC - MINIMUM HEIGHT OF ATTACHMENT 12'-0"
- (C) - MINIMUM 2" EMT, GALVANIZED, RIGID ALUMINUM OR SCHEDULE 40 ELECTRICAL GRADE PVC
- (D) - STRAPS MUST MATCH CONDUIT SIZE
MAXIMUM STRAP SEPARATION SHALL BE 30"
- (E) - MINIMUM GROUND ROD SIZE SHALL BE 5/8" x 8' COPPER OR GALVANIZED WITH SUITABLE CLAMP
- (F) - STAPLES SHOULD BE A MAXIMUM OF 8" APART
- (G) - WEATHERHEAD MUST BE WITHIN 24" OF ATTACHMENT POINT
NEC-230-51
- (H) - #3/0 COPPER MINIMUM, 75°C RATED INSULATION. NEUTRAL MUST BE STRIPPED BACK 2" OR MARKED WITH WHITE TAPE
GROUND WIRE SHALL HAVE MINIMUM 2' SLACK FROM POLE AND HAVE NO SHARP BENDS

(I) - WEATHERPROOF HUB

(J) - 3' SLACK IN DRIP LOOP

MEMBER FURNISHED, OWNED AND INSTALLED

- (A) - MINIMUM GROUND WIRE SIZE #4 COPPER COILED TO TIE TO MEMBERS DISCONNECT
- (B) - NEMA 3R OR BETTER WITH SUITABLE BRACKET OR TREATED WOOD BRACE AND MAXIMUM 150 AMPERE LOCKABLE DISCONNECT PROVIDED BY MEMBER
- (C) - ALL CONDUIT NIPPLES SHALL BE METAL
- (D) - BELLED BUSHING WIRE PROTECTOR IN ALL CONDUIT OPENINGS
- (E) - MEMBER MUST GO UNDERGROUND FROM METER BASE
- (F) - BOTTOM OF DISCONNECT SHALL BE 18" MINIMUM HEIGHT ABOVE GRADE
- (G) - LONG SWEEP ELBOW SUPPLIED BY MEMBER IF REQUIRED
- (H) - GALVANIZED METAL CHANNEL BONDED TO POLE GROUND
- (I) - MINIMUM #6 AWG COPPER WITH SUITABLE CONNECTORS FOR EQUIPMENT BONDING JUMPERS
- (J) - MINIMUM HEAVY TREATED 4" x 4" WOOD POST OR 3" RIGID GALVANIZED METAL PIPE
- (K) - GENERATOR MAST SHALL BE GROUNDED WITH A MINIMUM #6 AWG COPPER AND SUITABLE CONNECTORS TO A 5/8" x 8' COPPER GROUND
- (L) - BREAKER TO CO-GENERATION SHALL BE RATED FOR BACK FLOW OR FUSED MAY NOT BE MARKED LINE/LOAD
- (M) - SYSTEMS WITH BATTERIES REQUIRE ENGINEERING REVIEW

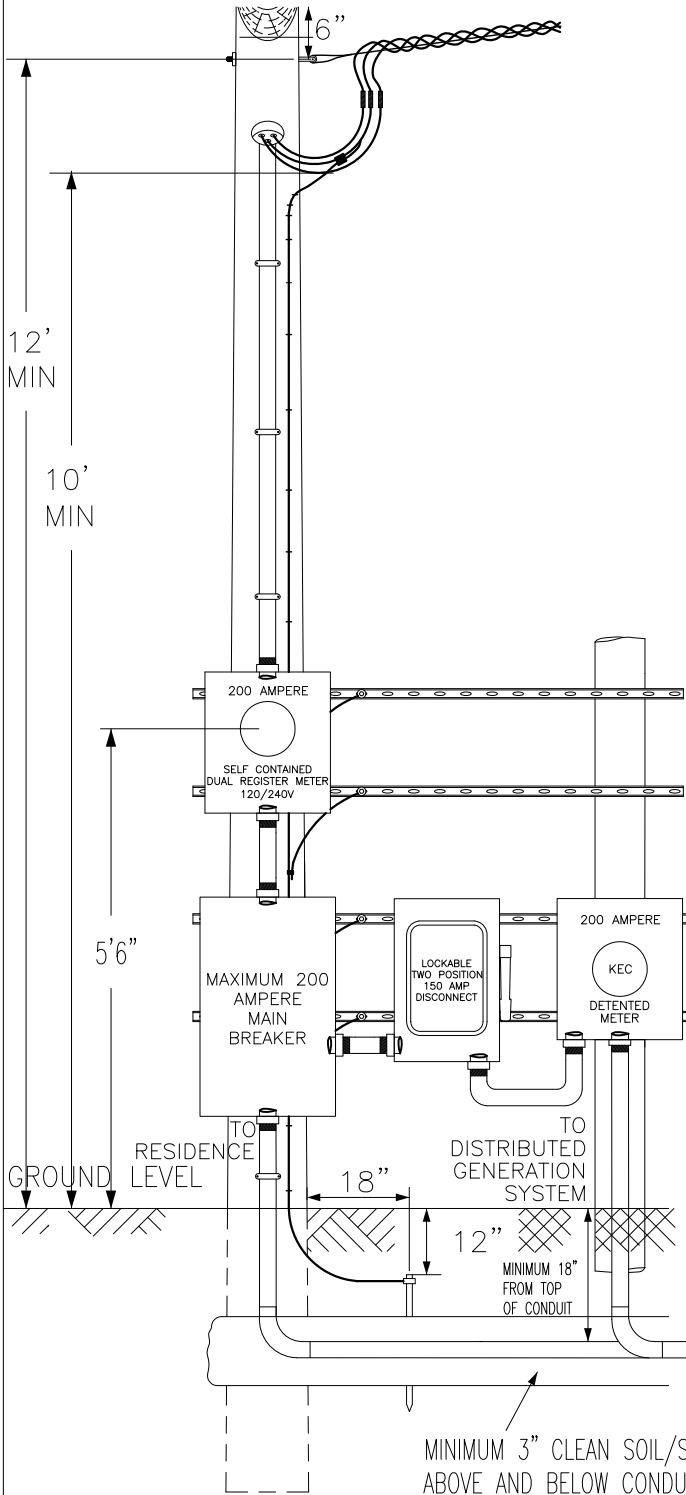

KARNES ELECTRIC COOPERATIVE, INC.

200 AMPERE 120/240 VOLT
DISTRIBUTED GENERATION (25 KVA OR LESS)

DATE: 08-01-16

KARNES CITY OFFICE (830)780-3952

PLEASANTON OFFICE (830)569-5538

